

RIBATTITORE DOPPIO

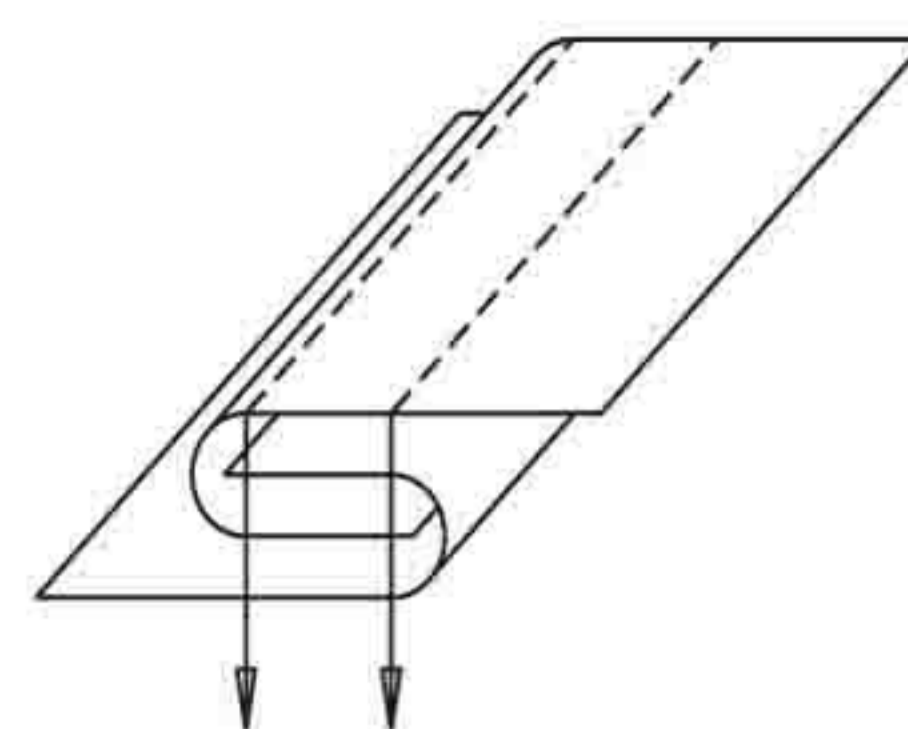

DOUBLE RABATTEUR

DOUBLE LAP SEAM FOLDER

GUIA DE SOBRECARGAR DOBLE

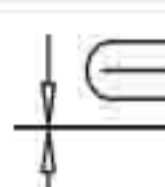

57 RIBATTITORI

CODICE			mm. 	inch. 			
20001			4,8	3/16		L/M/MH/H	
			6,4	1/4		L/M/MH/H/XH	

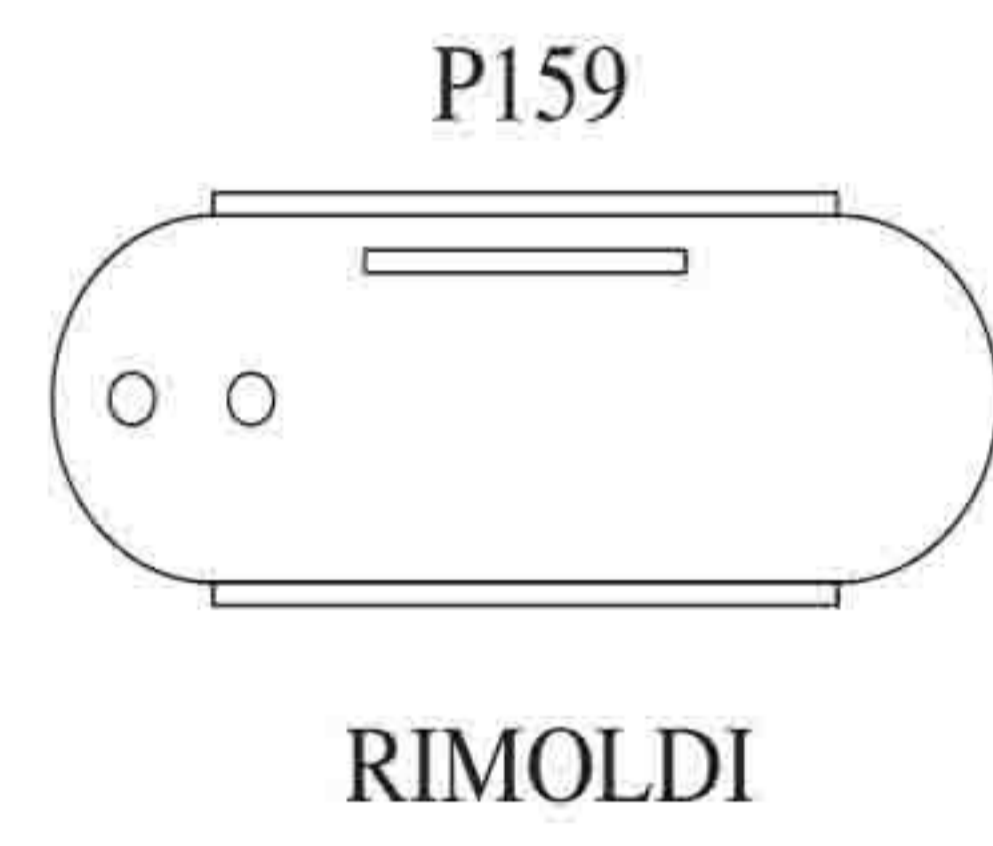
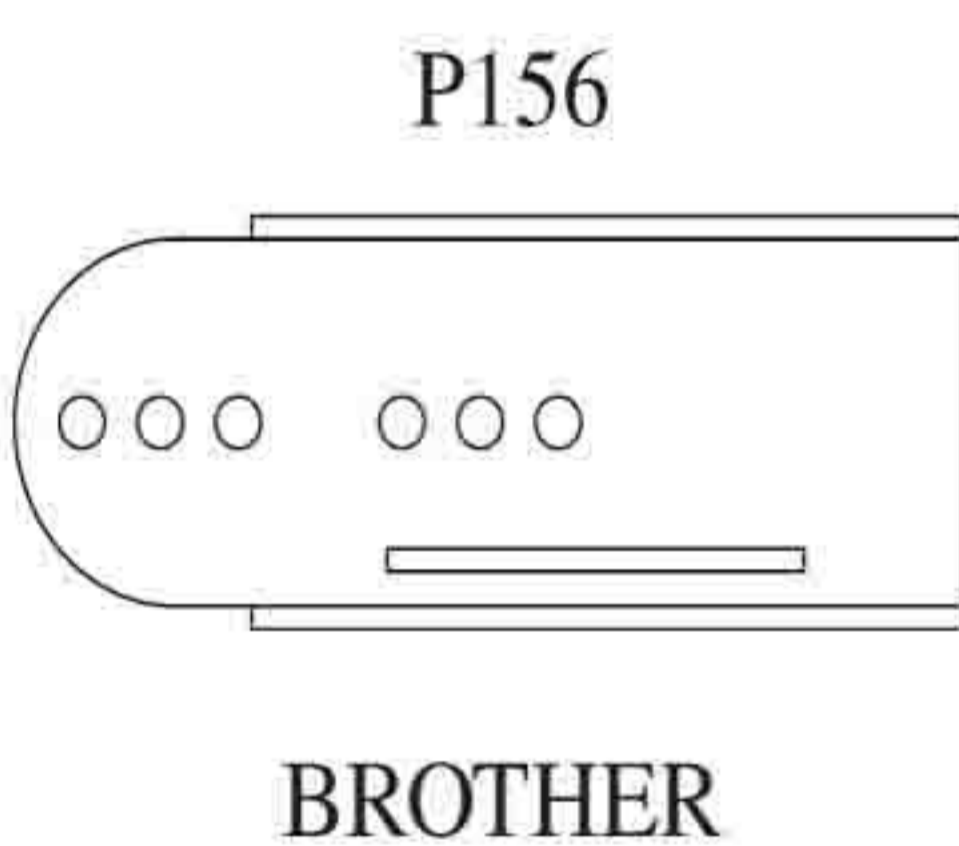
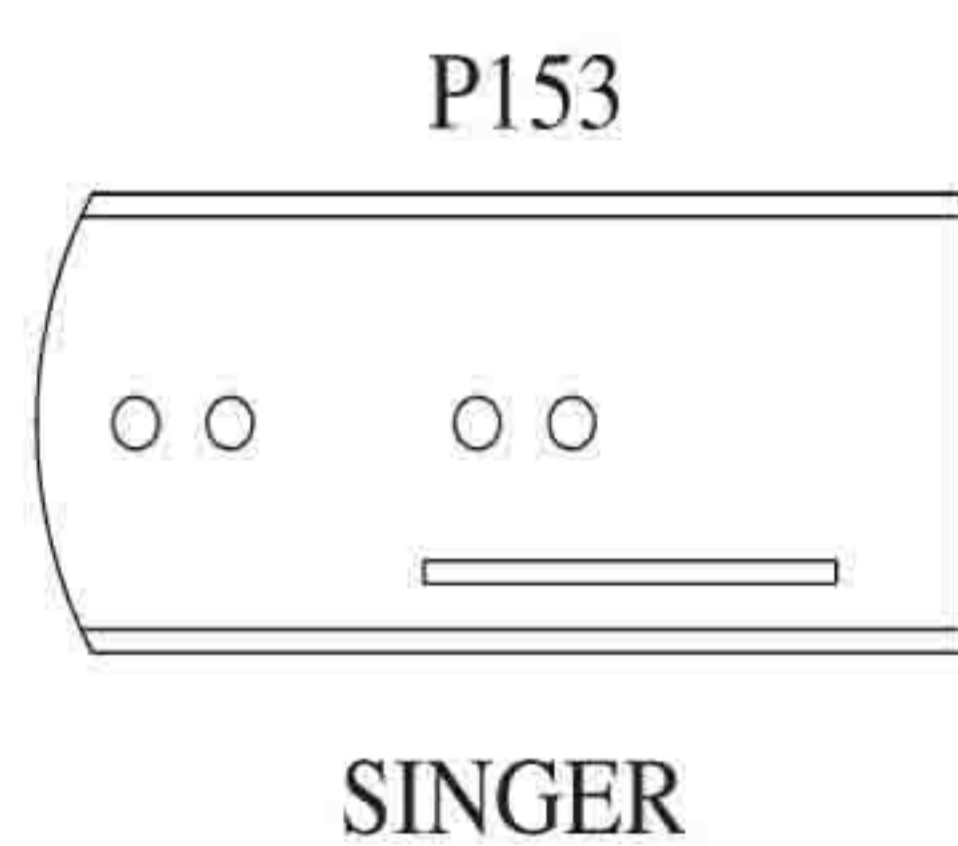

Il ribattitore inverso viene costruito su richiesta.
 The inversed lap seam folder is avaiable on request.
 Le double rabatteur inverse est disponible sur commande.
 La guía de sobrecargar invertida viene construida sobre demanda.

RIBATTITORE DOPPIO

DOUBLE RABATTEUR

DOUBLE LAP SEAM FOLDER

GUIA DE SOBRECARGAR DOBLE



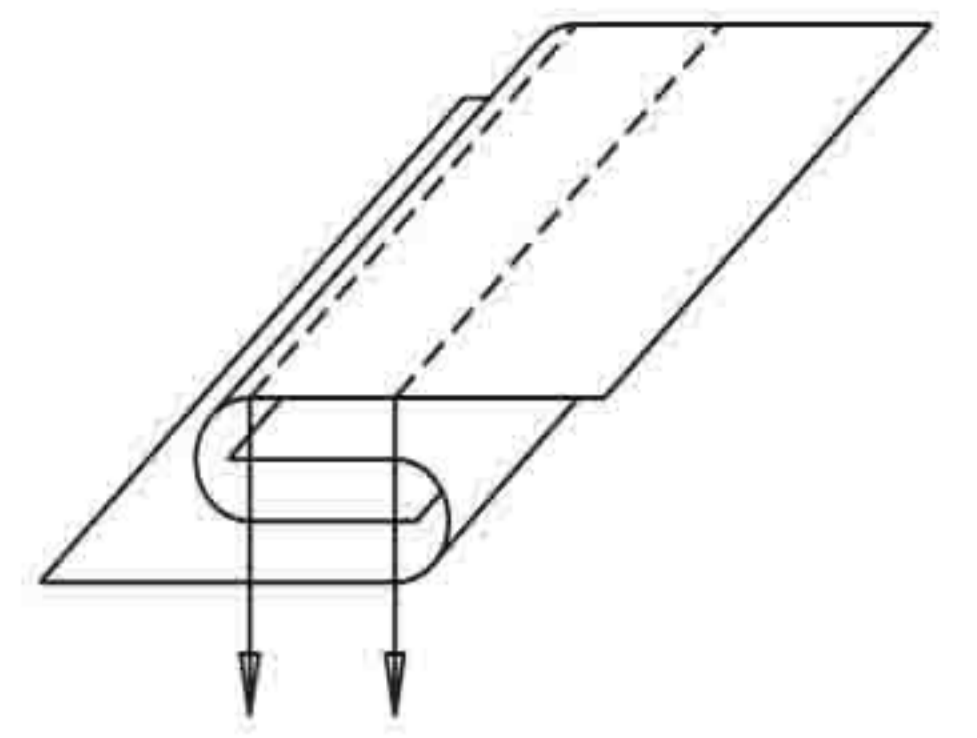

*P530



*P540

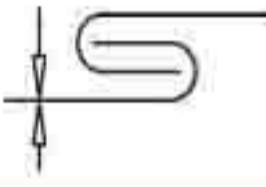

*P550

CODICE		*	mm. 	inch.			
28501			6,4	1/4	M/MH/H/XH		
28501/1kit	YAMATO DT30 UNION SPECIAL 35800	P530					
28501/2kit	RIMOLDI 184	P540					
28501/3kit	RIMOLDI 264	P550					
						<p>Il ribattitore inverso 28502 viene costruito su richiesta. The inversed lap seam folder 28502 is available on request. Le double rabatteur inverse 28502 est disponible sur commande. La guía de sobrecargar invertida 28502 viene construida sobre demanda.</p>	



RIBATTITORE DOPPIO PER SINGER 261

GUIDE A DOUBLE ENCASTREMENT POUR SINGER 261

DOUBLE LAPPED FELLING FOLDER FOR SINGER 261

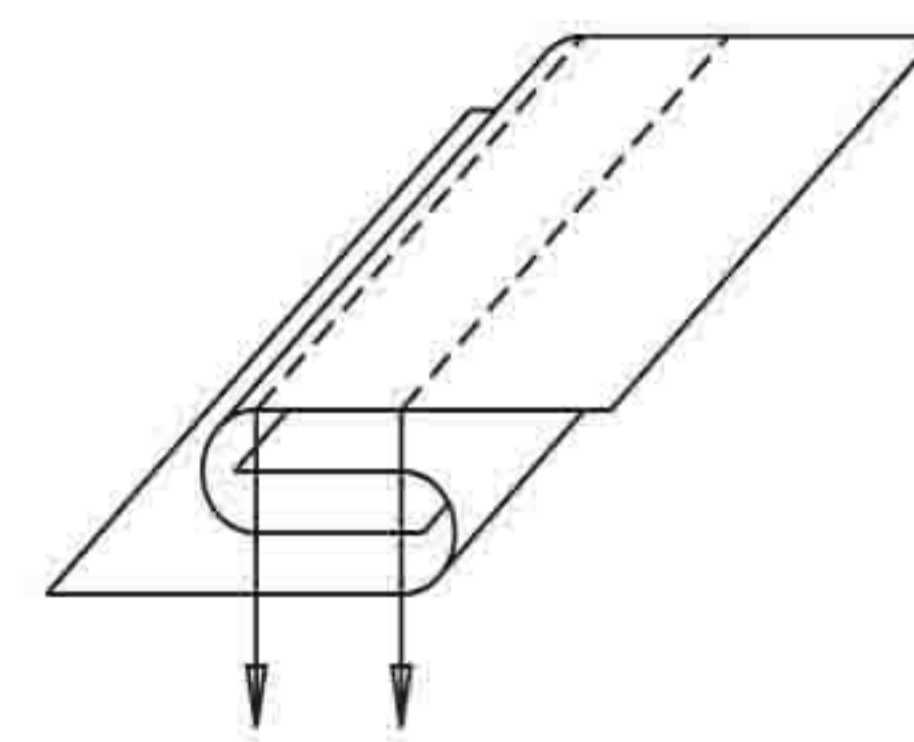
GUIA A DOBLE SOBRECARGADO PARA SINGER 261

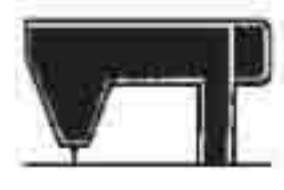

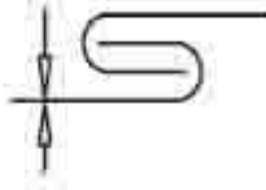
CODICE			mm. 	inch.			
28501/4kit	SINGER 261		6,4	1/4	M/MH/H/XH		

GUIDA REGOLABILE PER ASSEMBLAGGIO

GUIDE REGLABLE POUR ASSEMBLAGE

ADJUSTABLE ATTACHMENT FOR ASSEMBLING OPERATIONS

GUIA REGULABLE PARA EL ENSAMBLAGE

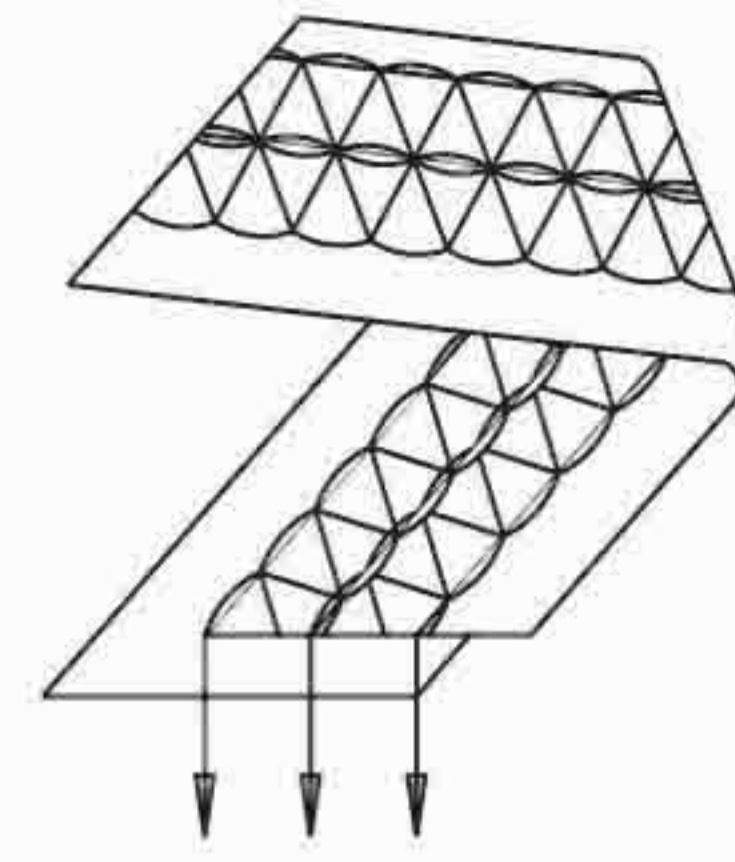

CODICE



mm. inch.



13020

0÷15 0÷19/32

L/M/H

RIBATTITORE PER MACCHINE PFAFF PIANE A 2 AGHI

RABATTEUR POUR PFAFF 2 AIGUILLES

LAP SEAM FOLDER FOR 2 NEEDLES FLAT BED PFAFF MACHINES

GUIA DE SOBRECARGAR PARA MAQUINAS PFAFF PLANAS DE 2 AGUJAS

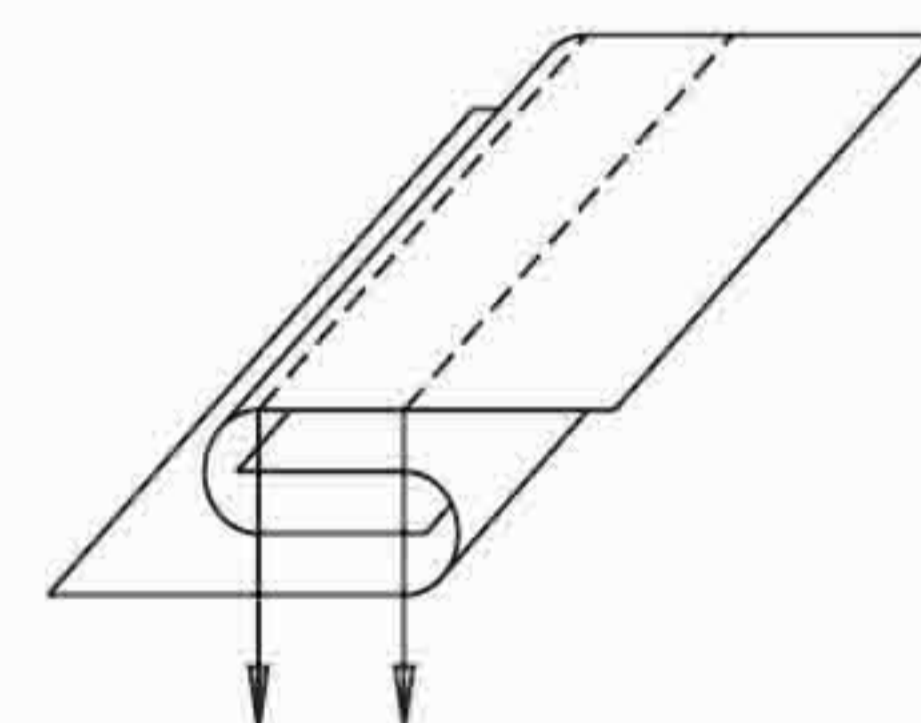
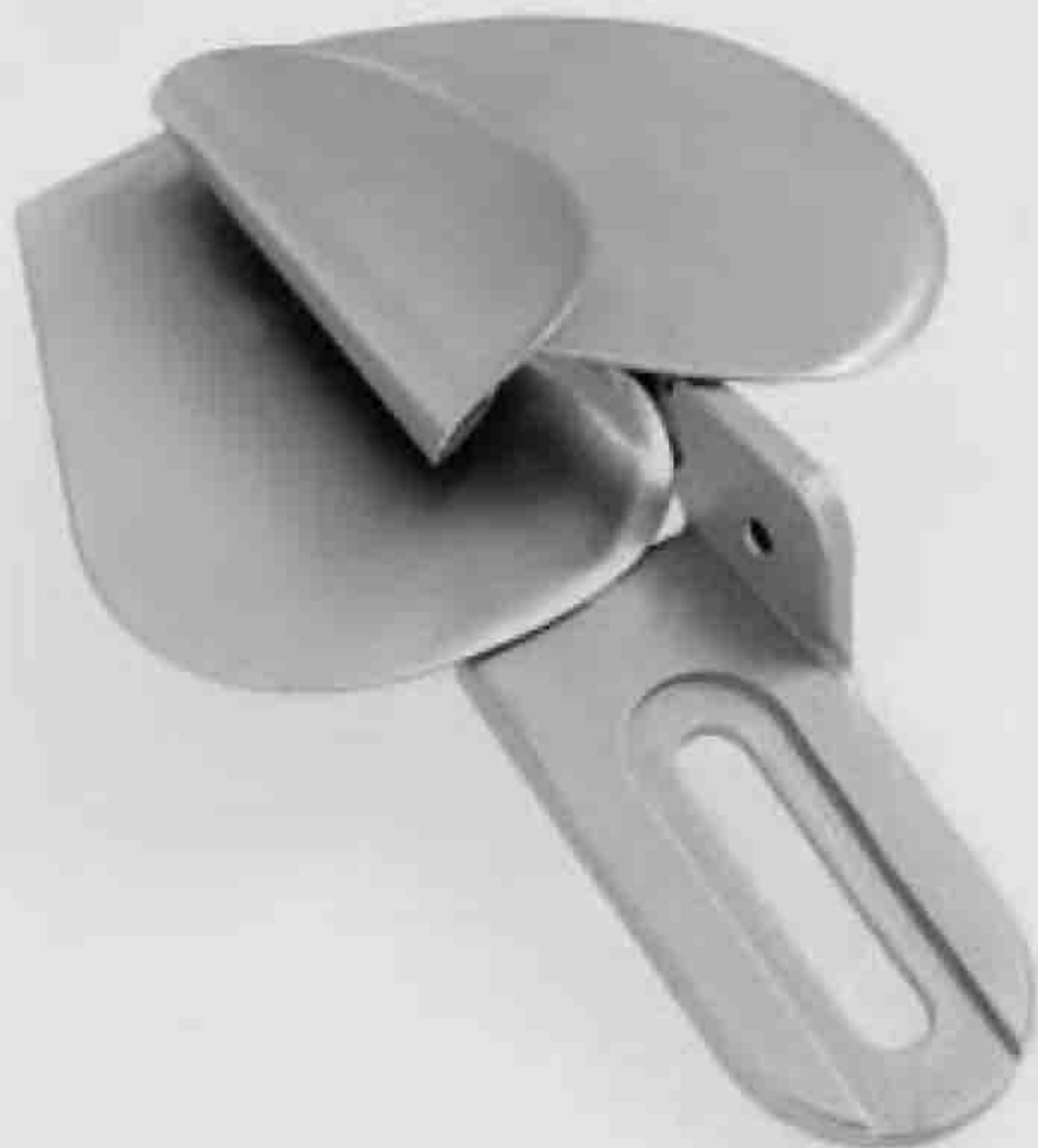

CODICE

18501

**COSTRUITO A RICHIESTA
MANUFACTURED ON REQUEST
CONSTRUIT SUR DEMANDE
CONSTRUIDO SOBRE DEMANDA**

RIBATTITORE DOPPIO

DOUBLE RABATTEUR

DOUBLE LAP SEAM FOLDER

GUIA DE SOBRECARGAR DOBLE

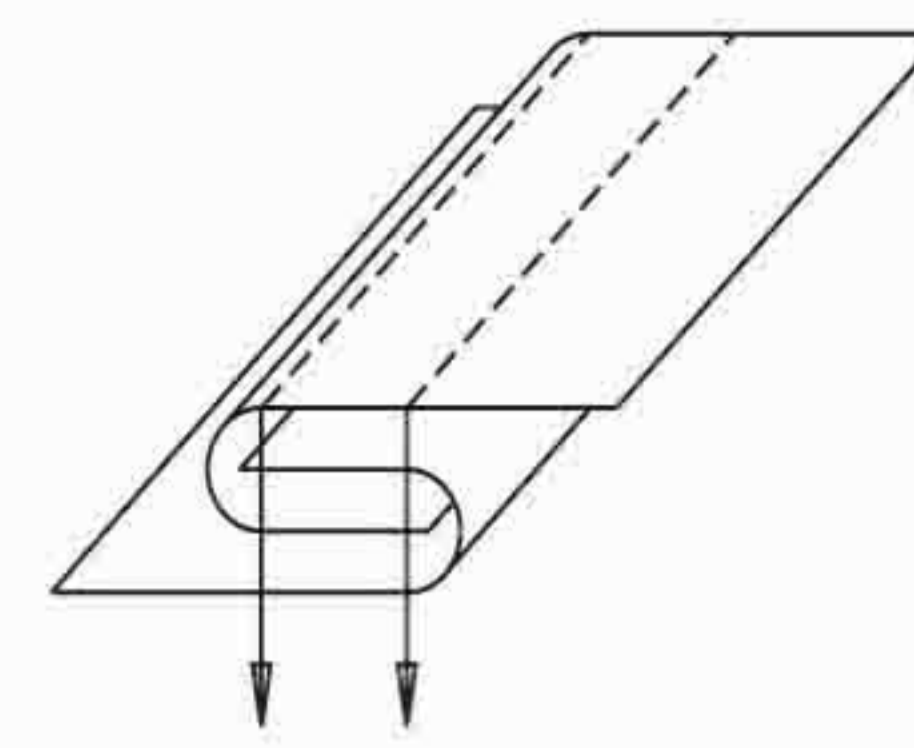
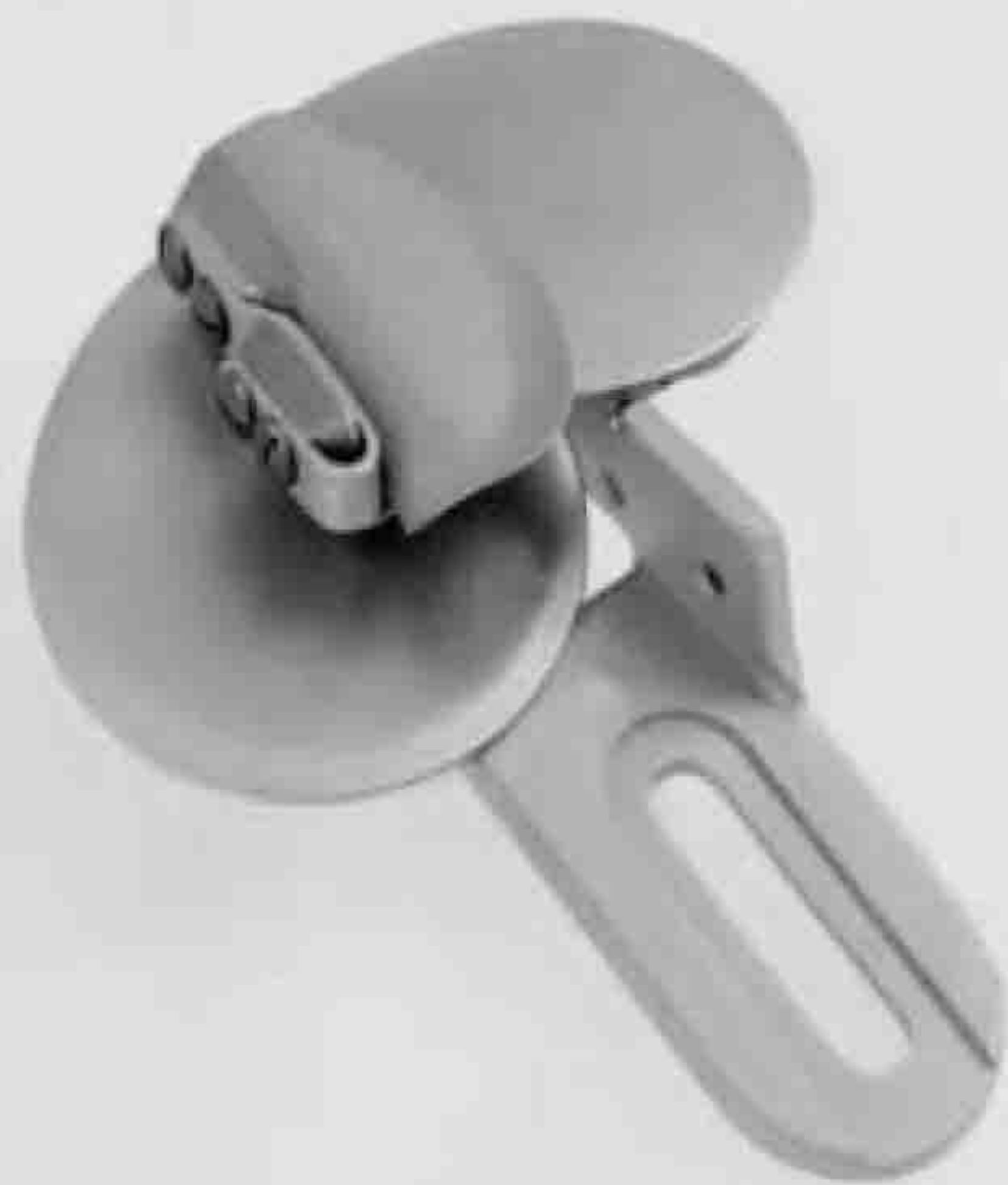

CODICE

19001

**COSTRUITO A RICHIESTA
MANUFACTURED ON REQUEST
CONSTRUIT SUR DEMANDE
CONSTRUIDO SOBRE DEMANDA**

RIBATTITORE PER CARRE' CAMICIA

GUIDE POUR EMPIECEMENT DE CHEMISES

YOKE ATTACHMENT

GUIA PARA EL CANESU DE LAS CAMISAS

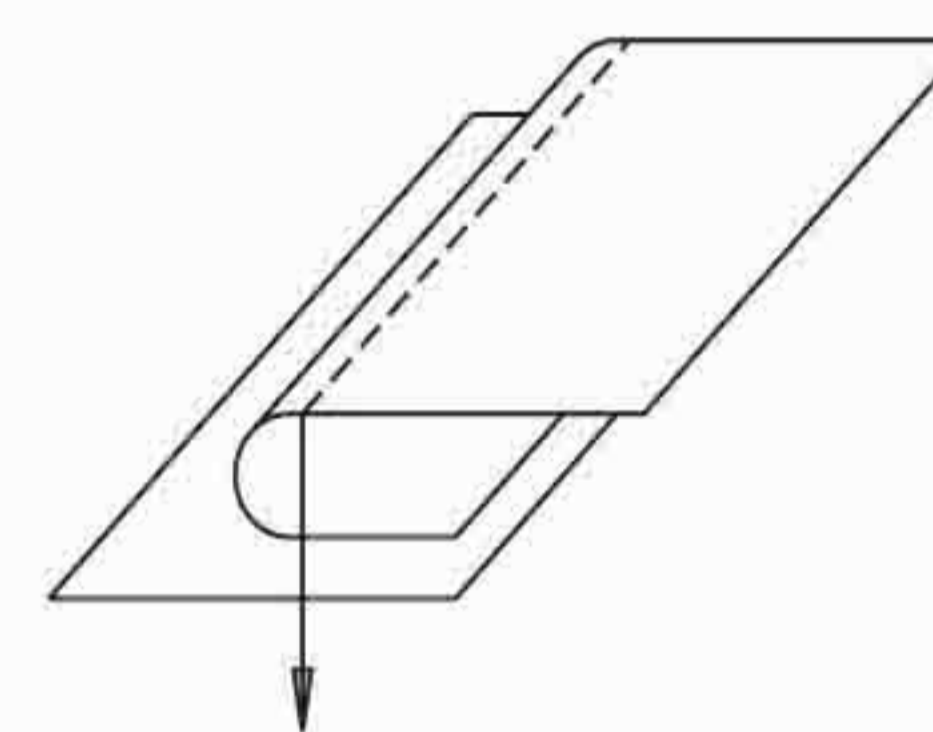

CODICE



20100

mm. inch.

7

9/32

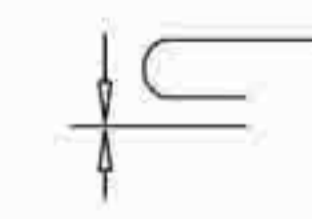

L/M/H

10

25/64

L/M/H

12

15/32

L/M/H

GUIDA PER CAMICERIA

GUIDE POUR MONTER MANCHES PAR FAUSSE COUTURE RABATTUE

FOLDER TO INSERT SLEEVE WITH IMITATION LAP SEAM

GUIA PARA CLAVAR MANGA CON COSTURA SOBRECARGADA IMITADA

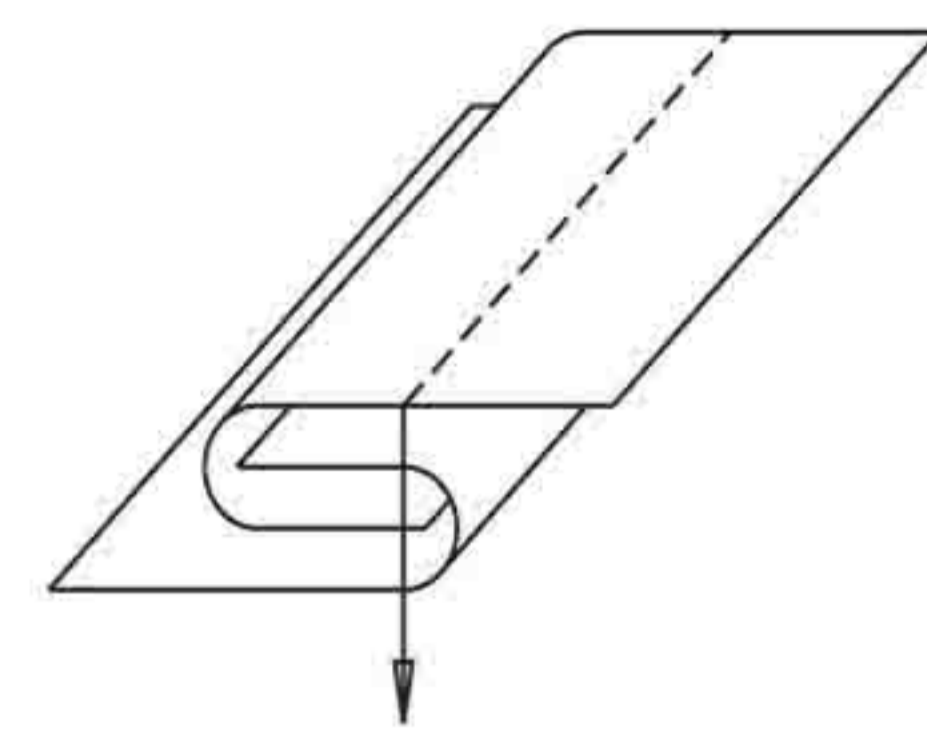
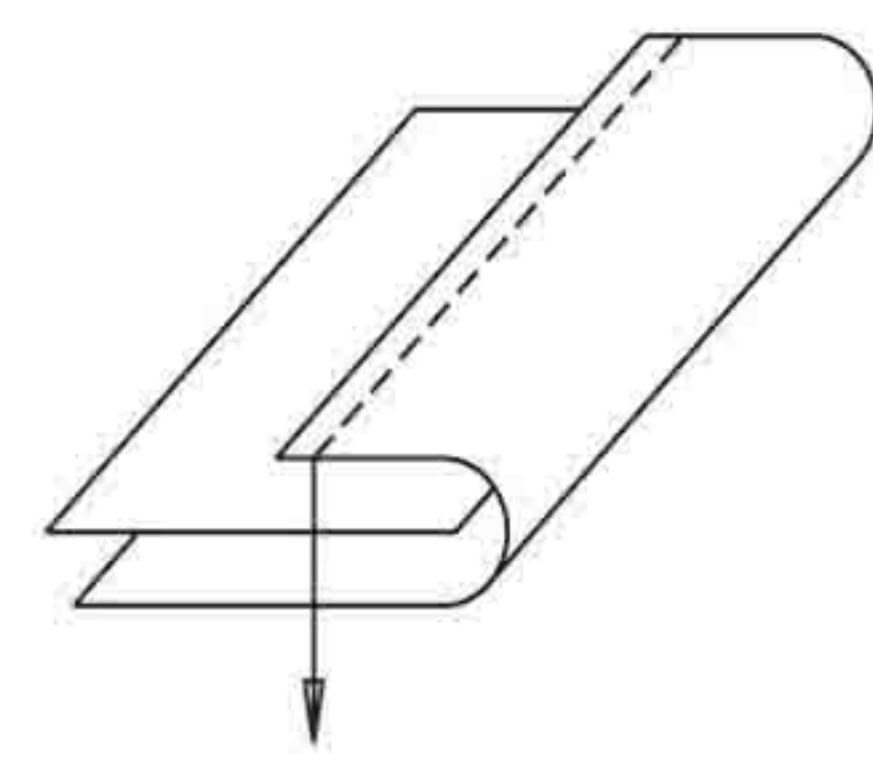
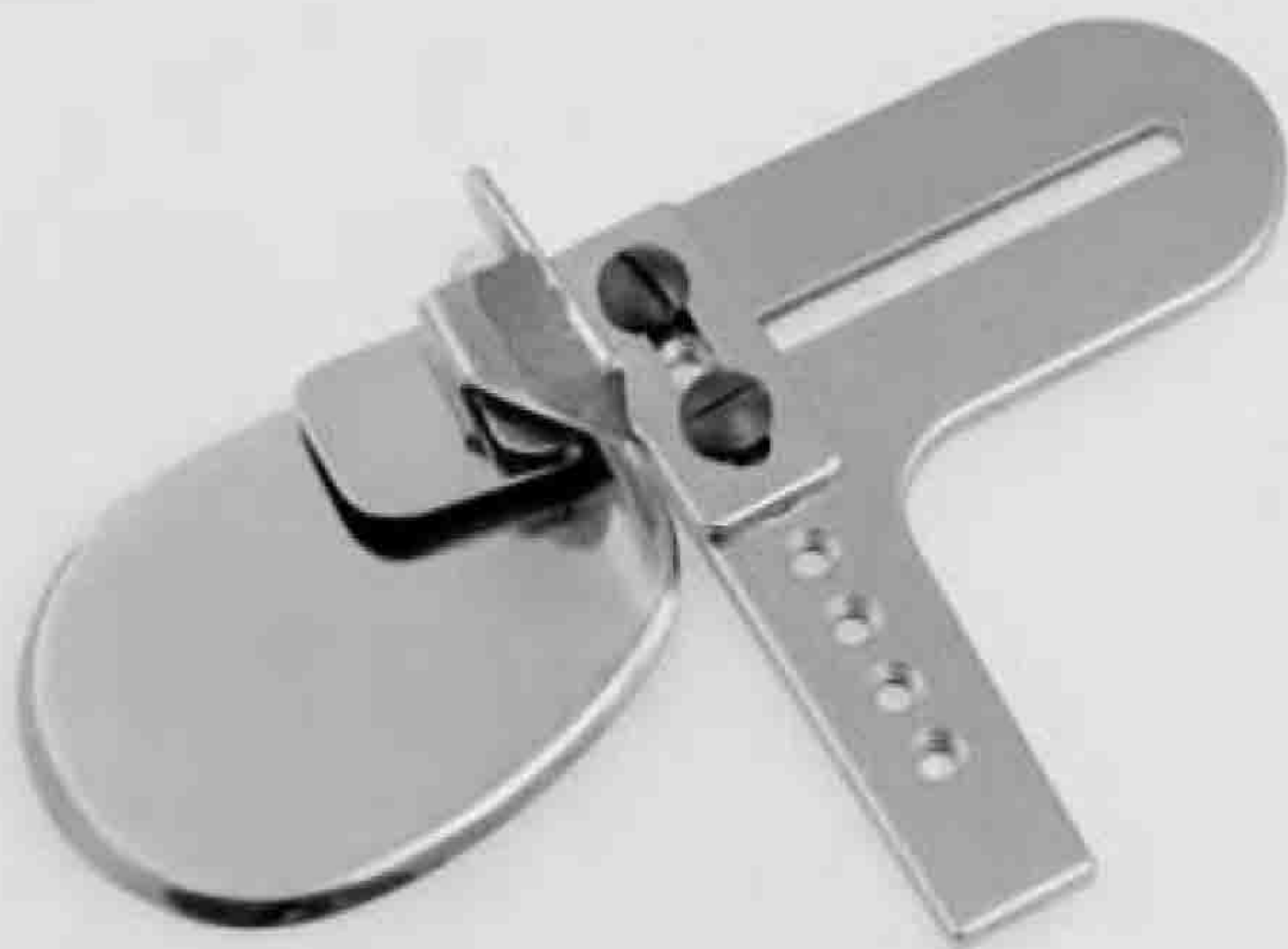

CODICE

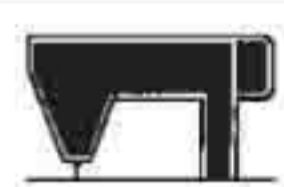

mm.  inch.

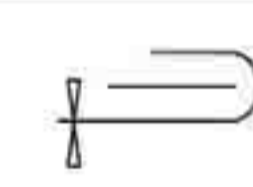

25601

7

9/32

L/M

10

25/64

L/M

13

33/64

L/M

15

19/32

L/M

GUIDA PER CAMICERIA

GUIDE POUR MONTER MANCHES PAR FAUSSE COUTURE RABATTUE

FOLDER TO INSERT SLEEVE WITH IMITATION LAP SEAM

GUIA PARA CLAVAR MANGA CON COSTURA SOBRECARGADA IMITADA

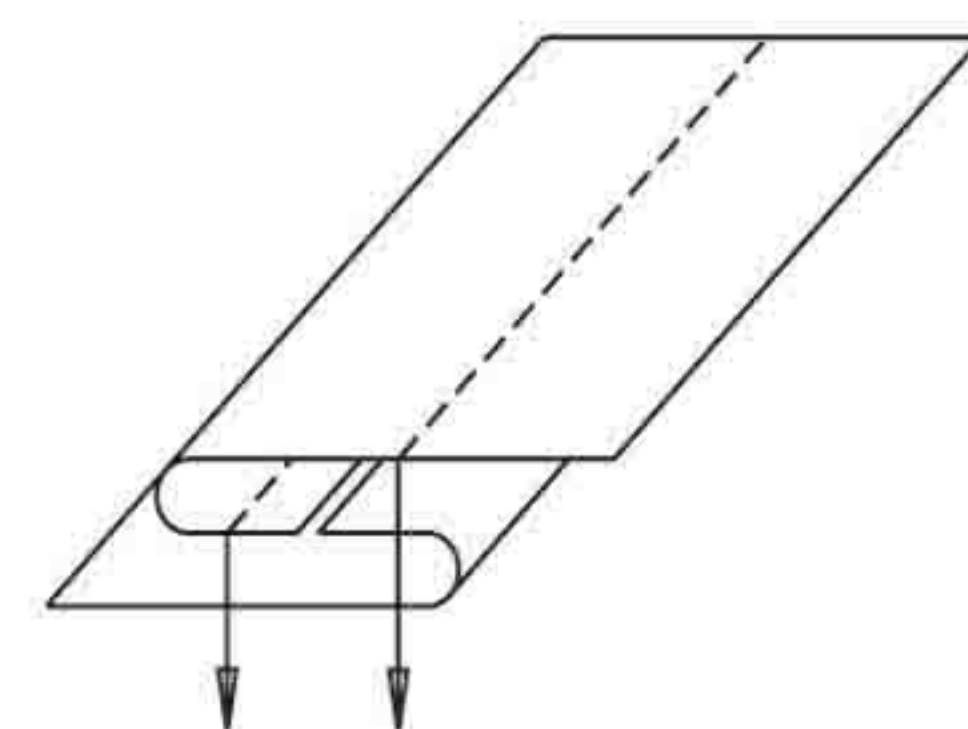
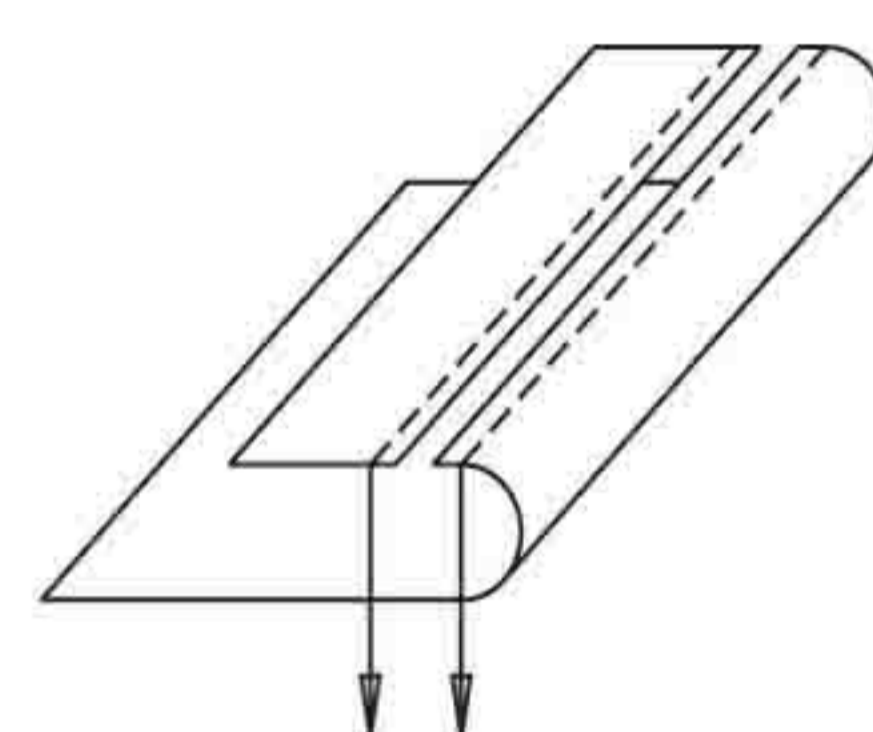
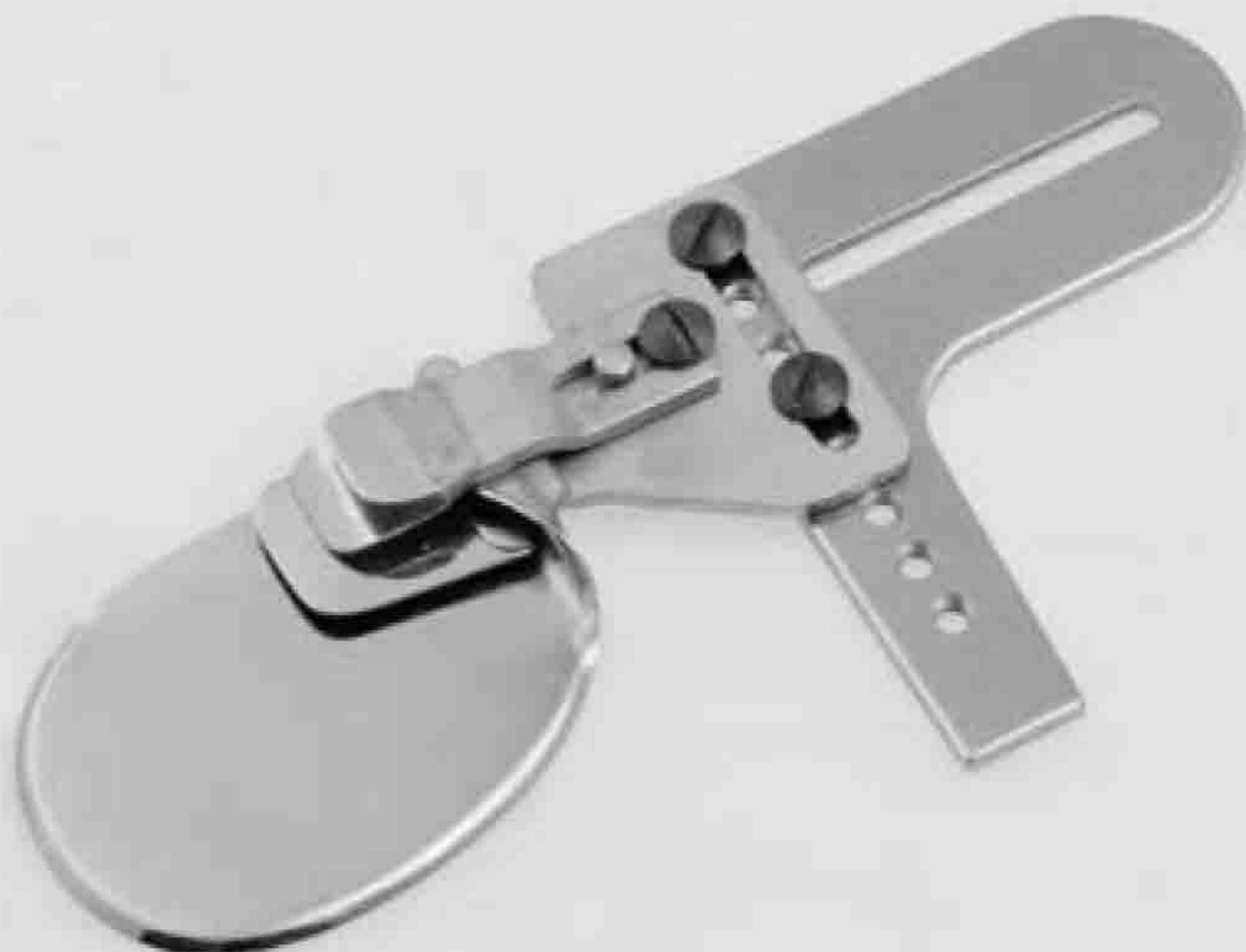

CODICE



mm.  inch.

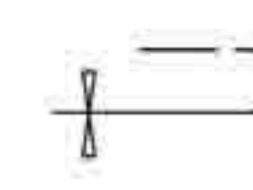

25701

8

5/16

L

10

25/64

L

12

15/32

L

GUIDA PER ATTACCATURA SPALLE

GUIDE POUR EMPIECEMENT DE CHEMISES

ATTACHMENT FOR SHOULDER APPLICATION

GUIA PARA CANESU DE CAMISAS

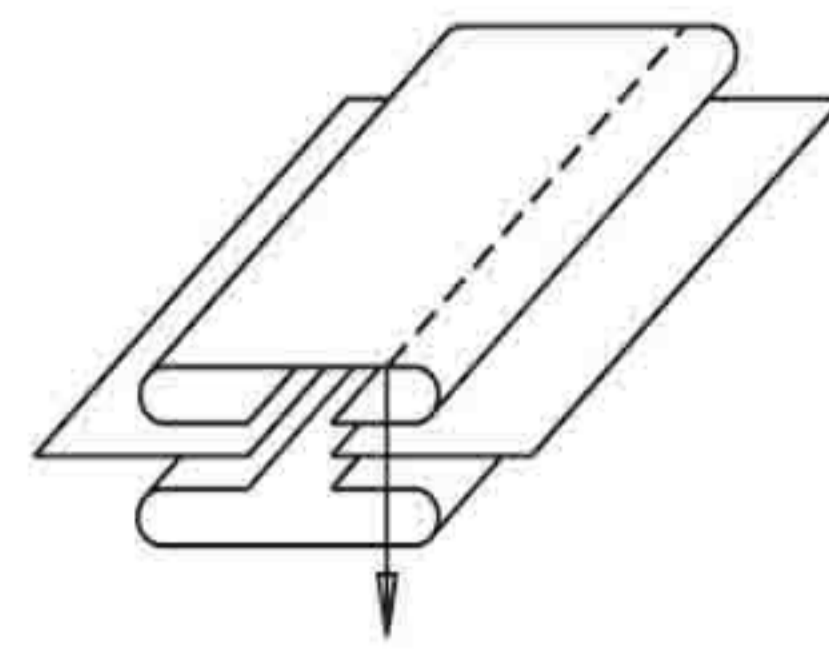
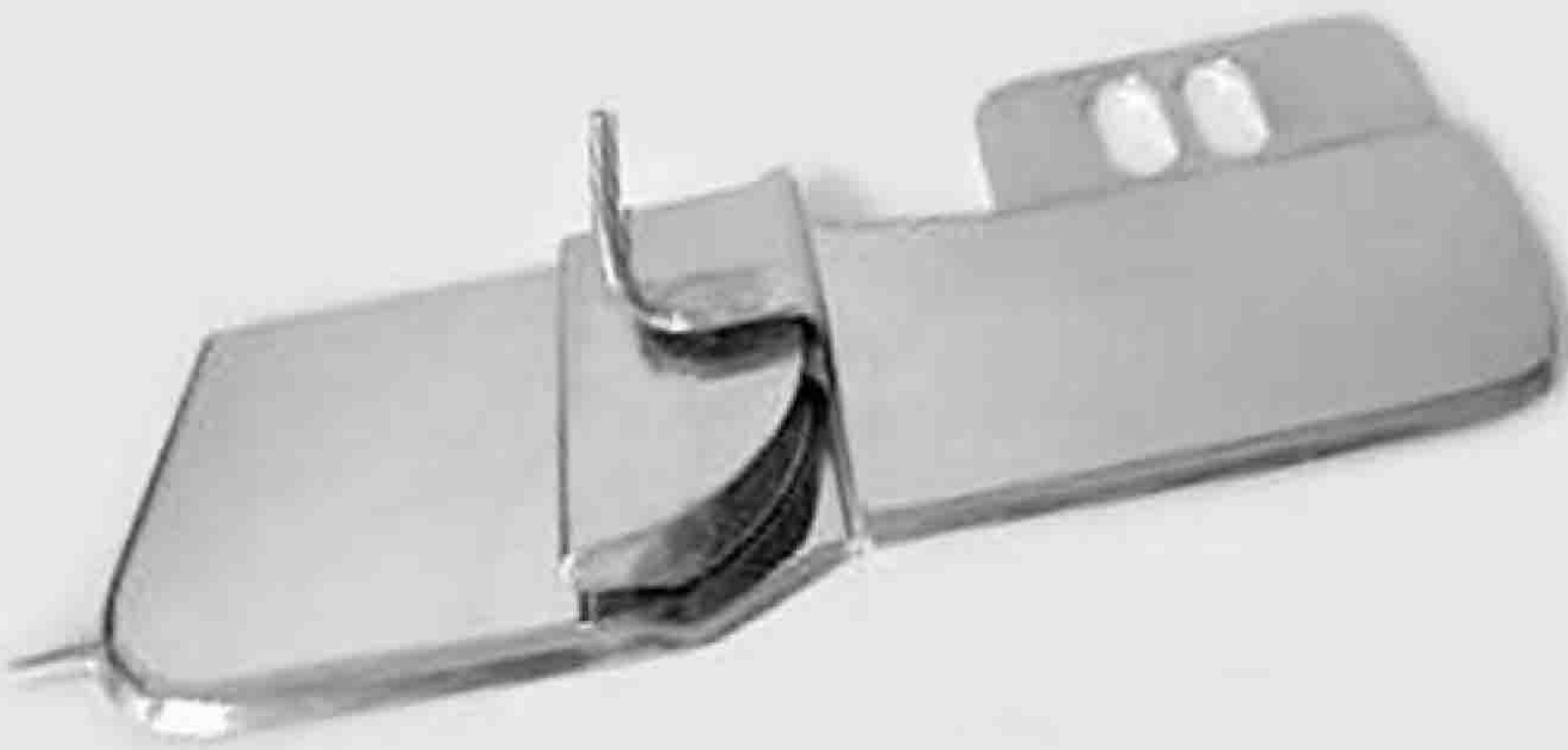

Y000036



A035

CODICE



mm.  inch.

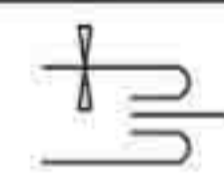

27300

10

25/64

L

GUIDA PER CARRE' CAMICIA

GUIDE POUR EMPIECEMENT DE CHEMISES

YOKE ATTACHMENT

GUIA PARA CANESU DE CAMISAS

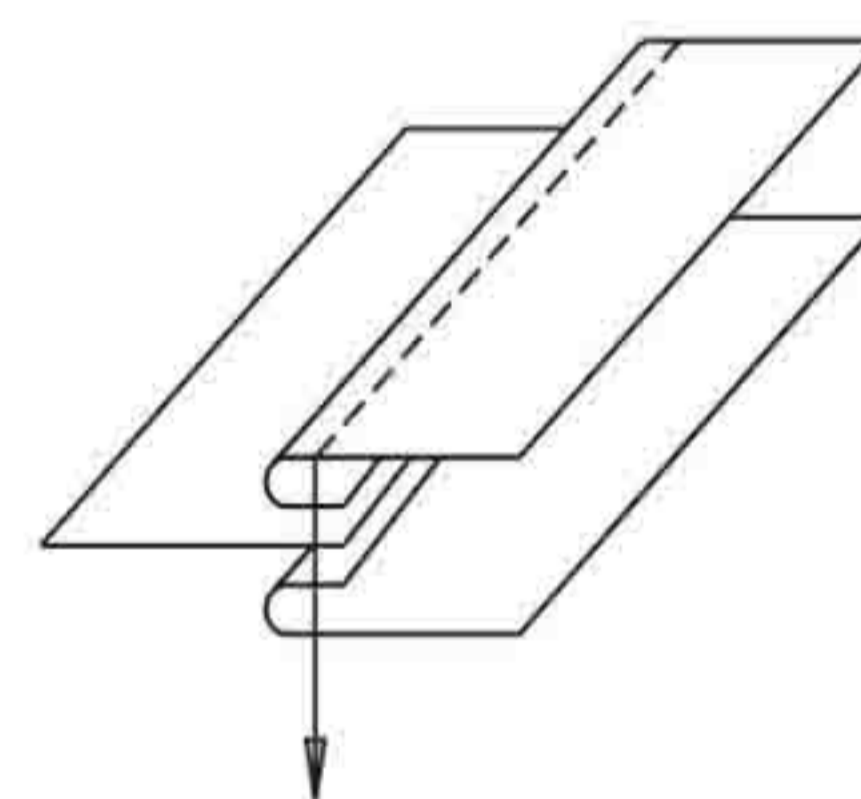
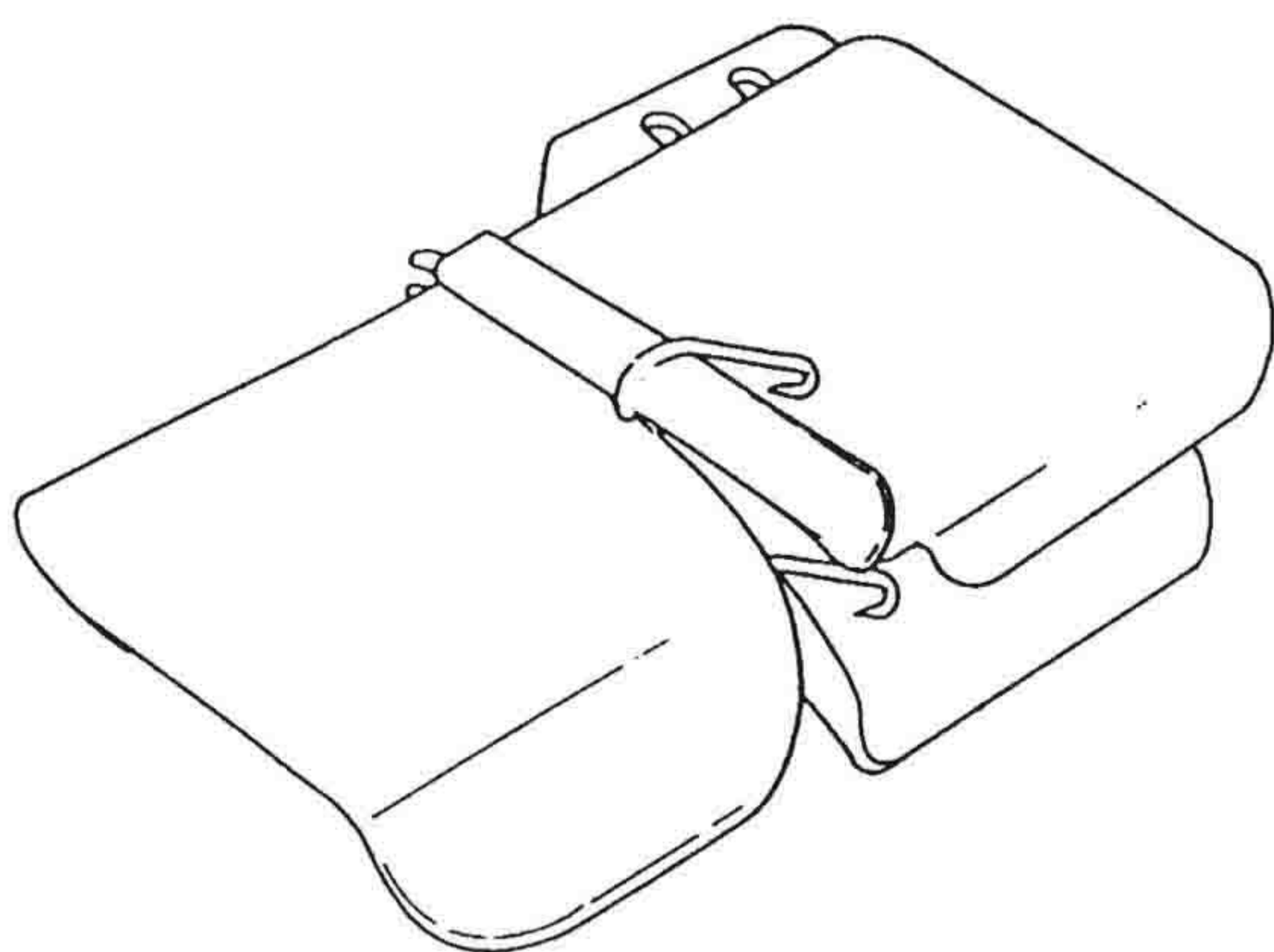

Y000036



A035

CODICE

27301

**COSTRUITO A RICHIESTA
MANUFACTURED ON REQUEST
CONSTRUIT SUR DEMANDE
CONSTRUIDO SOBRE DEMANDA**